

MMP 70

MMP 71

Microprocessor controller
for water softening plants



Operating Instructions

CONTENTS

GENERAL NOTES	1
Description of displays, indicators and operating features	1
Installation and commissioning	2
Control sequences	2
Settings	2
BASIC PROGRAMMING	3
1. Operating mode - Single filter/alternate filter mode	3
2. Regeneration delay	3
3. Electrical control of the regeneration valves with the MMP 70	4
3. Electrical control of the regeneration valves with the MMP 71	6
4. Premature regeneration triggering	6
5. Supplementary program	7
6. Triggering supplementary program	7
7. Impulse emitting water meter	7
8. Plant capacity (00---)	8
9. Plant capacity (--000)	8
10. Regeneration time stage I	8
11. Regeneration time stage II	8
12. Regeneration time stage III	9
13. Regeneration time stage IV	9
OPERATION BY PLANT PERSONNEL	9
ENTER OPERATING DATA	9
Raw water hardness	9
Time	10
Interval triggering	10
Regeneration delay	10
DISPLAYS AT THE TOUCH OF A BUTTON	11
Raw water hardness	11
Time	11
Regeneration days	11
Regeneration triggering	11
ILLUMINATED DISPLAYS	11
Residual soft water quantity	11
Operation	11
Draw-off	11
Regeneration	11
MANUAL CONTROL FOR SERVICING	12
Regeneration start	12
Fast run	12
Regeneration stop	12
Filter change-over without starting program	12
Additional connection facility	12
TECHNICAL APPENDIX	13
Example of circuitry for a single filter plant with PS valve	13
Programming example - Single filter system	13
Example of circuitry for an alternate filter plant with 4-stage valve	15
Programming example - Alternate filter system	15
Example of circuitry - MMP 71	16
BASIC PROGRAMMING DATA	Cover
TECHNICAL DATA	Cover

GENERAL NOTES

The MMP 70, MMP 71 (surface mounted on wall) and MMP 70 E, MMP 71E (flush mounted in control panel) controllers can be used with single filter and alternate filter mode water softening plants.

DESCRIPTION OF DISPLAYS, INDICATORS AND OPERATING FEATURES

1 Power switch

This switches the unit "on" and "off". When the switch is in the OFF position the outputs are also dead.

2 Appliance fuse

This fuse protects the outputs from overload or short circuit (max. M4A; for 230V/24V units M0.63A).

2' Output fuse

Only for 230V/24V units. Protects the 24 V outputs (max. M2.5A).

3 Keypad

These buttons are used to program the controller and call up status reports.

4 Security button

This button must be kept depressed when the controller is programmed. In order to make unauthorised or inadvertent changes to the basic programming more difficult, this button is located in the terminal box of the surface mounted unit. In the flush mounted unit it is located on the right of the keypad.

5 Display window

Current plant and programming data is indicated by the red digital display.

6 Indicator: DRAW-OFF

The yellow lamp lights up whenever an impulse is emitted by the water meter.

7 Indicator: OPERATION

This indicator shows which filter is currently operational.

8 Indicator: REGENERATION

This indicates the regeneration status of the filter currently undergoing regeneration.

9 RESET pins

see page 3, 13, 15 and 16.

MMP 70 and MMP 71

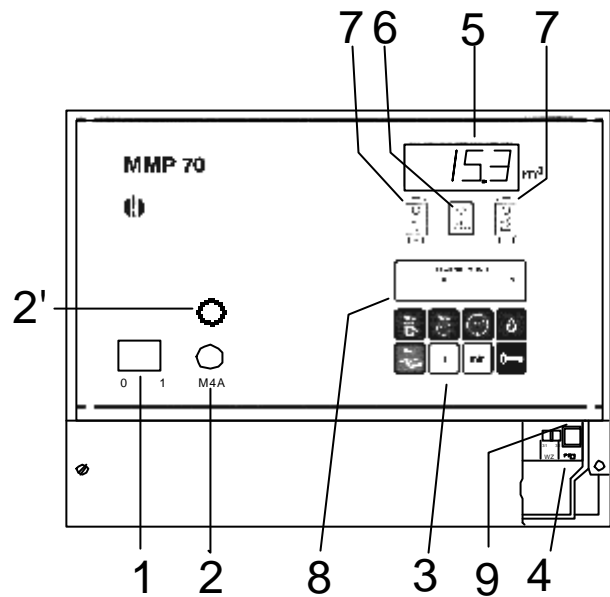

MMP 70 E and MMP 71 E

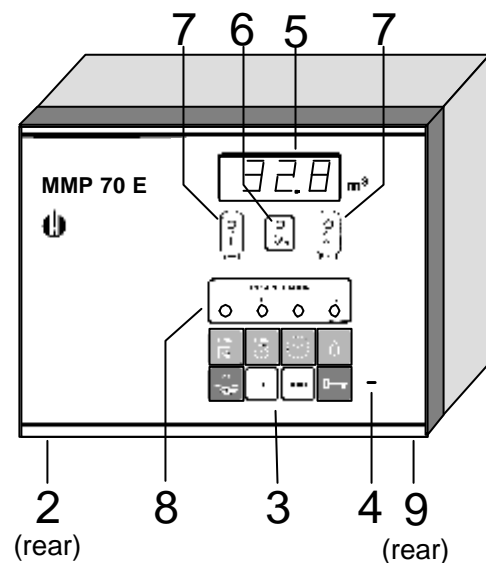

INSTALLATION AND COMMISSIONING

The installation and commissioning should be carried out by qualified personnel!

The controller must be installed in compliance with the parameters stated in the technical data (e.g. ambient temperature) and operated to comply with the relevant standards (DIN, VDE, UVV) or in accordance with the regulations laid down by the individual country.

Protect the controller against excessive humidity, condensation and water-splash.

The cable to the water meter should be kept as short as possible and **clear of** power cables. In the vicinity of sources of strong electromagnetic radiation the instrument reading may be affected. In such cases separate measures must be taken to suppress interference.

Operate the controller strictly in accordance with the manufacturer's instructions.

After installation, program the controller with the characteristics and data specific to the plant (e.g. operating mode, plant capacity, etc.)

The basic data remains in permanent memory and is unaffected by power failure.

CONTROL SEQUENCES

The microprocessor controllers can be used for the following regeneration control sequences:

1. Time-dependent

Regeneration is triggered at a time set on the integrated timer. The correct time setting will be based on the calculated total capacity and daily consumption of soft water.

2. Volume-dependent

Regeneration is triggered after the consumption of a pre-set volume of soft water measured by an impulse emitting water meter.

3. Volume-dependent with time override

As 2 above, but with the option of triggering regeneration at set intervals (e.g. every three days) even though the pre-set volume of soft water has not been drawn off in full.

4. Volume-dependent with regeneration delay

As 2 above, but with triggering of regeneration delayed by the integrated timer.

5. Volume-dependent with regeneration delay and time override

As 4 above, but with the option of triggering regeneration automatically at set intervals (e.g. every three days).

SETTINGS

Operating mode

Enter 'single' or 'alternate' filter operation.

Impulse emitting water meter

Enter the impulse rate of the water meter.

Time

Enter current time.

Plant capacity

Enter specific soft water capacity between 10 - 99990 g CaCO₃.

Raw water hardness

Enter the current raw water hardness from 20 to 990 ppm CaCO₃.

Electrical control of regeneration control valves

Enter control valve type.

Regeneration delay

Enter 'with' or 'without' regeneration delay.

Premature regeneration

Enter premature regeneration for a soft water reserve between 0 - 50%.

Time-dependent regeneration

Enter:

- a) no regeneration triggering
- b) regeneration interval between 1 and 14 days.

Regeneration time

Enter a regeneration time.

Duration of regeneration stages

Enter stages I to IV, each of which can be 1 - 99 minutes.

Supplementary program start

Enter a start time before the start, at the start or at the end of the last regeneration phase.

Supplementary program

Enter the duration of the supplementary program.

BASIC PROGRAMMING

Be sure to make a note of your basic programming data on the sticker in the terminal box cover (in the case of the flush mounted version, on the rear of the unit) and on the last page of this manual.

To call up the **factory setting**, switch on the device with the security button depressed or bridge the reset pins with the security button depressed.

Operating data (programming steps 1 - 13) is to be entered in the sequence described below:

MMP 70 and MMP 71 surface mounted unit

Open the terminal box cover and press the red security button (4). (see Page 1)

MMP 70 E and MMP 71E flush mounted unit

Open the front panel door and press the red security button (4) next to the "Key" button using a slender implement (ball point pen). (see Page 1)

This enables changes to be made in basic programming. The display window will then show for example, "1.0". This means that the programming step 1 ° **Operating mode** has been set to the value 0 = 'single' filter mode. If, for instance, you want to change the mode to 'alternate' operation, keep the security button depressed and press the "min" button until "1.1" appears in the display. If you want to proceed to the next programming step ° **Regeneration delay**, keep the red security button depressed and press the "Key" button. "2.0" = No regeneration delay or "2.1" = Regeneration delay will come up on the display.

The programming steps are described below. The basic data entered in these programming steps will be saved to memory until changes are made to the basic program:

PROGRAMMING STEP 1 OPERATING MODE

Press the red security button until the following is displayed:

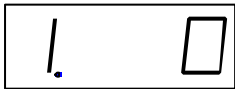

Single filter mode = only one filter (filter 1) in operation

or

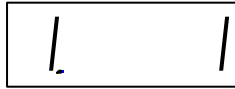

Alternate filter mode = alternating with one filter at a time in operation

Keep the red security button depressed while pressing the "min" button to select the desired operating mode, e.g. "1.0" or "1.1". (Pre-setting is 0)

PROGRAMMING STEP 2 REGENERATION DELAY

Keep the red security button depressed while pressing the "Key" button until the following is displayed:



No regeneration delay

or

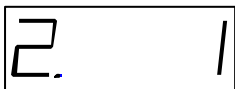

Regeneration delay

In single filter mode the service valve remains open and is not closed until regeneration starts. In 'alternate' mode the plant switches immediately to the reserve filter and regeneration of the exhausted filter is subsequently triggered at the set time.

or

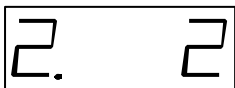

Regeneration delay (single filter mode only)

In single filter mode the service valve is closed immediately.

Keep the red security button depressed while pressing the "min" button to select the desired regeneration delay "2.0", "2.1" or "2.2". (Pre-setting is 0)

If a regeneration delay has been set, the volume of water consumed will be registered, but regeneration will not occur until the set time, e.g. 20.00 hrs (cf. Regeneration delay). This prevents regeneration being triggered at an unfavourable time.

In order to prevent frequent overrunning when regeneration delay has been set, premature triggering should be set in programming step 4.

PROGRAMMING STEP 3 *ELECTRICAL CONTROL OF THE REGENERATION VALVES WITH THE MMP 70 AND MMP 70 E*

Important note!

This is the description of programming step 3 for the MMP 70 and MMP 70 E. To enter the desired mode for the electrical control of the regeneration valves, keep the red security button depressed while pressing the "min" button:

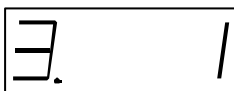

4-stage valves with change-over switch

Regeneration valves or pilot distributors with 4 mechanical positions controlled by an electrical change-over switch.

or

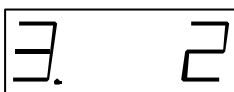

2-stage valves

Regeneration valves with 2 mechanical positions controlled by an electrical switch.

or

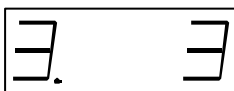

4-stage valves with impulse switch

Regeneration valves or pilot distributors with 4 mechanical positions controlled by an electrical impulse (impulse duration = 40 seconds).

or



Valves with integrated program motor

Regeneration valves with their integrated program motor are started by an external impulse. The duration of the starting impulse is stipulated in programming step 10 = regeneration time stage 1 (1 - 99 minutes).

or

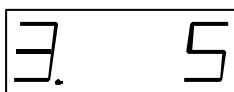

Valves for partial salting

Regeneration valves with 4 mechanical valve positions. Regeneration time stage I = draw-off chemicals (see programming step 10) is automatically adapted to actual consumption. In the event of a manual start the total set time always applies.

Regeneration sequence 1

Indicated stage	Function	Mechanical position
I	Backflush	1
II	Draw-off chemicals	2
III	Fast rinse	3
-	Service	4

Regeneration sequence 2

Indicated stage	Function	Mechanical position
I	Draw-off chemicals	1
II	Rinse	1
-	Service	2

Regeneration sequence 3

Indicated stage	Function	Mechanical position
I	Backflush	1
II	Draw-off chemicals	2
III	Fast rinse	3
-	Service	4

Regeneration sequence 4

Indicated stage	Function	Mechanical position
I	Backflush (impulse)	Start
II	Draw-off chemicals	
III	Fast rinse	
-	Service	

Regeneration sequence 5

Indicated stage	Function	Mechanical position
I	Draw-off chemicals	1
II	Purge	2
III	Backflush	3
-	Service	4

or



5-stage valves e.g. PVE impulse switch

Regeneration valves or pilot distributors with 5 mechanical positions controlled by an electrical impulse (impulse duration = 40 seconds).

Regeneration sequence 6

Indicated stage	Function	Mechanical position
I	Backflush	1
II	Draw-off chemicals	2
III	Slow rinse	3
IV	Fast rinse	4
-	Service	5

or



5-stage valves with change-over switch

Regeneration valves or pilot distributors with 5 mechanical positions controlled by an electrical change-over switch. (The 5th valve position is controlled by an additional microswitch connected to terminal 8 or terminal 8' = automatic reset).

Regeneration sequence 7

Indicated stage	Function	Mechanical position
I	Backflush	1
II	Draw-off chemicals	2
III	Slow rinse	3
IV	Fast rinse	4
-	Service	5

or

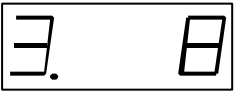

Controlled via 2 pilot valves

In 'alternate' filter mode the output **Supplementary program** (terminals 17/18/19) is assigned to the "Chemicals" function and, accordingly, no supplementary program is possible.

Regeneration sequence 8

Filter 1:(1= energised condition, 0=de-energised condition)

Indicated stage	Terminal 5,6,7	PR terminal
I	1	0
II	0	1
III	0	1
IV	1	1
Service	0	0

Filter 2:(1= energised condition, 0=de-energised condition)

Indicated stage	Terminal 5',6',7'	Supplementary program 1 terminal
I	1	0
II	0	1
III	0	1
IV	1	1
Service	0	0

Important note!

Instead of regeneration valves it is also possible to use appropriately actuated pilot distributors, e.g. PVH or PVP for change-over switching Programming: "3.1", or "3.6" for an electrical pilot distributor of type PVE with 5 positions. (Pre-setting is 1)

PROGRAMMING STEP 3 *ELECTRICAL CONTROL OF THE REGENERATION VALVES WITH THE MMP 71 AND MMP 71 E*

This section describes programming step 3 for the MMP 71 and MMP 71 E!

In this programming step the valve positions for the 5 stages are programmed in the following sequence:

Service - Regeneration stages I, II, III and IV. (Suitable for use in conjunction with Culligan or Technino valves.)

To enter the desired mode to control the 5 stages of the valve positions, keep the red security button depressed while simultaneously pressing the "Key" button.

Initially, the solenoid valve control is entered for the 'service' stage.

For example, the following is displayed:

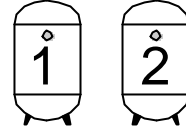

and the green indicator lamps "Filter 1" and "Filter 2" light up.

To enter the desired control of the three 'normally closed' solenoid valves V1, V2 and V3 in the operating position, press the following buttons:

- "Manual reg." for Valve 1
- "h" for Valve 2
- "min" for Valve 3

1 = valve "ON" (energised)

0 = valve "OFF" (de-energised)

Example:

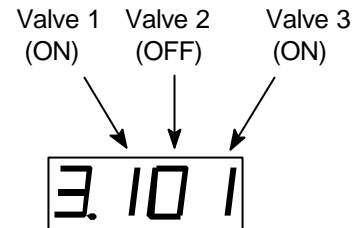

After the 'service' stage, the four regeneration stages I to IV are called up by depressing the red security button while pressing the "Key" button.

The indicator lamps "Regeneration I to IV" light up in sequence and the green indicator lamps for filter 1 and filter 2 "switch off".

The subsequent valve stages are entered in a similar manner as described for the "service" stage.

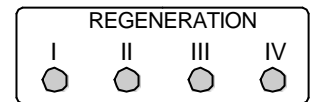

When selecting an 'alternate' filter mode (Service/Standby), it is necessary only to program filter 1. Filter 2 will automatically reflect similar valve functions after a change-over has taken place.

Example of a typical programming sequence:

The sequence times for regeneration stages I to IV are entered in programming steps 10 to 13. Enter "0" minutes if any of the three regeneration steps (11 - 13) are not required. A minimum of '01' minutes **only** can be entered in step 10.

	V1	V2	V3
Service	0	0	0
Regeneration I	1	0	0
Regeneration II	1	1	1
Regeneration III	0	1	0
Regeneration IV	0	0	0

PROGRAMMING STEP 4 *P R E M A T U R E REGENERATION TRIGGERING*

Keep the red security button depressed while pressing the "Key" button until, for example, the following is displayed:

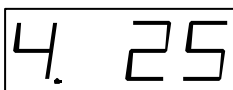

regeneration triggered at 25% soft water reserve

To enter a desired premature regeneration initiation, keep the red security button depressed while pressing the "h" or "min" button to obtain values for soft water reserve between 0 and 50%. (Pre-setting is 00)

In a single filter plant this mode is selected in combination with the programming step 2 "Regeneration delay" in order to ensure that there is a guaranteed supply of soft water for the next working day.

If premature regeneration initiation is not desired you should enter a 0.

PROGRAMMING STEP 5 SUPPLEMENTARY PROGRAM

Keep the red security button depressed while pressing the "Key" button until, for example, the following is displayed:

5.085

Supplementary program = 85 minutes

To enter the desired supplementary program time stage keep the red security button depressed while pressing the "h" (10 digits) or "min" (1 digit) button.

Values from 0 to 250 minutes can be entered. (Pre-setting is 001)

If a 0 is entered, supplementary program will not be activated.

PROGRAMMING STEP 6 TRIGGERING SUPPLEMENTARY PROGRAM

If you have entered a 0 in programming step 5, programming step 6 will be skipped.

Keep the red security button depressed while pressing the "Key" button until, for example, the following is displayed:

6. 2

Supplementary program triggering with regeneration stage II

To enter the triggering time for the supplementary program keep the red security button depressed while pressing the "min" button. (Pre-setting is 1)

The following triggering times for the supplementary program can be entered:

- 00** = On exhaustion of filter capacity with immediate change-over of service valves. Regeneration will not commence until expiry of the period of time entered in the programming step 5.
- or **0** = On exhaustion of filter capacity, the change-over of service valves and commencement of regeneration will not occur until the period of time entered in the programming step 5 has expired.
- or **1** = On commencement of regeneration stage I
- or **2** = On commencement of regeneration stage II
- or **3** = On commencement of regeneration stage III
- or **4** = On commencement of regeneration stage IV
- or **5** = On termination of the last regeneration stage

The period of duration of the supplementary program has already been entered in the programming step 5.

This note refers to the MMP 70 and MMP 70 E only!

If you entered a value 2 when selecting programming step 3, you cannot set a value 3 in programming step 6. You can only set a value 4 if you select a value 6 in programming step 3.

PROGRAMMING STEP 7 IMPULSE EMITTING WATER METER

Keep the red security button depressed and press the "Key" button until, for example, the following is displayed:

7. 4

Water meter with 10 litres/impulse

This table lists the applicable water meter ratings:

1	Water meter with 1 litre/impulse	5	Water meter with 50 litres/impulse
2	Water meter with 2.5 litres/impulse	6	Water meter with 100 litres/impulse
3	Water meter with 5 litres/impulse	7	Water meter with 500 litres/impulse
4	Water meter with 10 litres/impulse	8	Water meter with 1000 litres/impulse

Keep the red security button depressed and press the "min" button to select the desired impulse emitting water meter, e.g. "7. 1", "7. 2", "7. 3", "7. 4", "7. 5", "7. 6", "7. 7" or "7. 8". (Pre-setting is 6)

PROGRAMMING STEP 8 PLANT CAPACITY (00--)

5-digit capacities cannot be displayed in the inspection window beside the programming step, so for capacity settings over 990 g CaCO₃ the ten thousands and thousands are set first in step 8 and then the hundreds and tens in step 9.

Example:

Plant capacity = 5800 g CaCO₃

Enter 05 in programming step 8.

Enter 8 and 00 in programming step 9.

To enter the desired plant capacity in g CaCO₃, depress the red security button and press the "h" button until the ten thousands digit, e.g. 0, appears in the display window.

Now press the "min" button to set the thousands digit, e.g. until 5., is seen in the display window.

A digital display showing the number 8.05. The digits are in a simple, blocky font. The decimal point is positioned between the 8 and the 0.

You can specify plant capacities from 10 to 99990 g CaCO₃. (Pre-setting is 50)

PROGRAMMING STEP 9 PLANT CAPACITY (--000)

Keep the red security button depressed and press the "Key" button until, for example, the following is displayed:

A digital display showing the number 9800. The digits are in a simple, blocky font. There is no decimal point visible.

Hundreds and tens digits are entered by depressing the red security button and pressing the "h" button for hundreds, e.g. 8, and the "min" button for the tens, e.g. 0. (Pre-setting is 500)

Entering 05 in programming step 8 and 800 in programming step 9 sets a plant capacity of 5800 g CaCO₃.

Important note!

The capacity of **one** filter only is to be entered, irrespective of whether the plant is a 'single' or an 'alternate' filter plant.

PROGRAMMING STEP 10 REGENERATION TIME STAGE I

Keep the red security button depressed and press the "Key" button until, for example, the following is displayed:

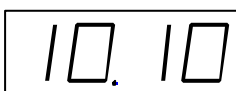
A digital display showing the number 10.10. The digits are in a simple, blocky font. The decimal point is positioned between the 0 and the 1.

Stage I = 10 minutes

To enter the desired regeneration time stage I keep the red security button depressed while pressing the "h" or "min" button.

Values from 1 - 99 minutes can be entered. (Pre-setting is 10)

PROGRAMMING STEP 11 REGENERATION TIME STAGE II

Keep the red security button depressed and press the "Key" button until, for example, the following is displayed:

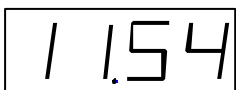
A digital display showing the number 11.54. The digits are in a simple, blocky font. The decimal point is positioned between the 1 and the 5.

Stage II = 54 minutes

To enter the desired regeneration time stage II keep the red security button depressed while pressing the "h" or "min" button.

Values from 1 - 99 minutes can be entered. (Pre-setting is 90)

PROGRAMMING STEP 12 REGENERATION TIME STAGE III

MMP 70 only!

If you have entered a 2 in programming step 3 when selecting electrical control of the regeneration valves, programming step 12 will be skipped.

Keep the red security button depressed and press the "Key" button until, for example, the following is displayed:



Stage III = 8 minutes

To enter the desired regeneration time stage III keep the red security button depressed while pressing the "h" or "min" button. Values from 1 - 99 minutes can be entered. (Pre-setting is 20)

PROGRAMMING STEP 13 REGENERATION TIME STAGE IV

MMP 70 only!

This programming step can only be selected if you have entered a 6 or 7 in programming step 3.

Keep the red security button depressed and press the "Key" button until, for example, the following is displayed:

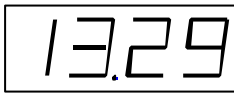

Stage IV = 29 minutes

To enter the desired regeneration time stage IV keep the red security button depressed while pressing the "h" or "min" button. Values from 1 - 99 minutes can be entered. (Pre-setting is 20)

Important note!

Be sure that the basic programming settings have been entered on the sticker inside the terminal box cover and on the final page of this manual.

On completion of basic programming replace the terminal box cover. All further data can be entered on the front panel keypad.

OPERATION BY PLANT PERSONNEL

ENTER OPERATING DATA



RAW WATER HARDNESS

To set raw water hardness press the green "Raw water hardness" button and the red "Key" button for 5 seconds until the displayed value flashes. Keep the red "Key" button depressed and press the green "Raw water hardness" button repeatedly until the value you want is displayed.

If central control valves with built-in blenders are installed, subtract residual water hardness from raw water hardness and enter this value.

Example: Raw water hardness = 450 ppm CaCO₃
Blend hardness (filter outlet) = 108 ppm CaCO₃
Setting = (450 - 108) ppm CaCO₃ = 342 ppm CaCO₃

Important note!

The microprocessor will not recalculate and display the amount of soft water available from the filter until after the completion of the next regeneration.

Accordingly, you should trigger the regeneration manually by pressing the blue "Reg. manual" button whenever you have reset raw water hardness.

TIME



The time is set by pressing the red "Key" button and the green "Time" button simultaneously for 5 seconds until the flashing time display appears. Keep the red "Key" button depressed and release the "Time" button. Now use the "h" (hours) and "min" (minutes) buttons to set the correct time in the display window.

Press the green "Time" button to view "Current time" in the display window at any time.

INTERVAL TRIGGERING

For time-dependent triggering enter a regeneration interval in days and a time as follows:

1. Day interval



Press the green "Days" button and the red "Key" button for 5 seconds until the display in the window flashes. Keep the red "Key" button depressed and press the green "Days" button repeatedly or continuously to enter the length of the interval you want in days (1 - 14 days). Enter 00 day for no interval triggering.

2. Regeneration time



Press the green "Reg.-time" button and the red "Key" button for 5 seconds until the display in the window flashes. Keep the red "Key" button depressed and press the "h" button repeatedly or continuously to enter the hours, then repeat with the "min" button to enter the minutes, for the time you want to set for regeneration to take place, e.g. 18.15.

The "regeneration interval" can now be called up in the display window at any time by pressing the green "Days" button and the "regeneration time" by pressing the green "Reg.-time" button. On the day set for regeneration the red indicator lamp "REGENERATION I" will start flashing from 00.00 hours onwards. This lamp lights up while regeneration is taking place.

When a plant is set for volume triggering it is advisable in addition, to set a "time-dependent" triggering in order to preclude bacteriological contamination over long, idle periods or to cover the eventuality of a water meter failure or repair.

NOTE

Any new "Regeneration interval" setting keyed in, will be displayed only after the completion of the programmed regeneration cycle.

REGENERATION DELAY

If a regeneration delay has been selected in the basic programming (step 2 = 1), both the current time and the selected starting time for regeneration must be entered.

The regeneration delay can then be applied if a regeneration proves undesirable for technical reasons during working hours.

Proceed as follows to make the setting:



Press the green "Reg.-time" button and the red "Key" button until the display in the window flashes. Keep the red "Key" button depressed and press the "h" button repeatedly or continuously to enter hours, repeat with the "min" button to enter minutes for the desired regeneration time, e.g. 18.15 (cf. regeneration interval).

The currently set time for triggering the delayed regeneration can be called up in the display window by pressing the green "Reg.-time" button. When a regeneration is due but still held up by the "delay" that has been set, the red indicator lamp "REGENERATION I" will flash.

During regeneration the indicator lamp of the relevant regeneration stage will light up.

Important note!

The time of the regeneration delay and the time of the interval triggering are the same.

DISPLAYS AT THE TOUCH OF A BUTTON

RAW WATER HARDNESS



Displays the set raw water hardness, e.g.:



200 ppm CaCO₃

TIME



Displays current time, e.g.:

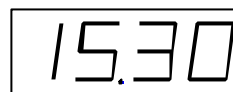

15.30 o'clock

DAYS



Displays the number of days to go before the next regeneration is triggered, e.g.:

This is only displayed when interval triggering was entered during setting.



3 days

REGENERATION TRIGGERING



The time set for regeneration is shown, e.g.:

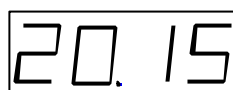

20.15 o'clock
(start)

This is only displayed when regeneration delay was selected in step 2 of basic programming or when interval triggering between 1 and 14 days was entered.

ILLUMINATED DISPLAYS

RESIDUAL SOFT WATER QUANTITY, e.g.:

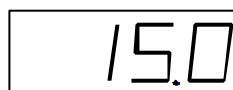

m³

During normal operation the remaining available volume of soft water from the filter until the next regeneration is continuously indicated in m³ in the display window.

OPERATION

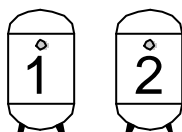

The green indicator lamps 1 or 2 will light up to indicate which filter is in operation at any one time.

DRAW - OFF



Every time an impulse is emitted by the water meter the yellow "Draw-off" indicator lamp lights up.

REGENERATION

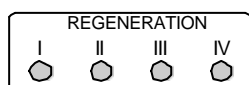

During regeneration of a filter the indicator lamps Regeneration I - IV light up in accordance with the time stages that have been entered.

When the first indicator lamp is flashing it means that regeneration will be initiated on the day at the set time.

MANUAL CONTROL FOR SERVICING

When the plant is commissioned or maintenance is subsequently carried out, there may be a need to start a manual regeneration for the following reasons: to run the regeneration sequence with multi-stage valves in a fast run mode, to abort the regeneration sequence or to effect a filter change-over.

REGENERATION START



To trigger an extra regeneration manually, press the blue button "Reg. manual" for 5 seconds until the red indicator lamp "Regeneration I" lights up. With alternate filter plants a filter change-over will occur at the same time.

FAST RUN

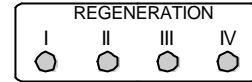

A fast run can be started only during a regeneration stage!
If a regeneration has been previously started manually, 1 minute must elapse before the fast run sequence can be initiated!

To initiate a regeneration fast run, press the blue "Reg. manual" button and the red "Key" button simultaneously for 5 seconds until the red indicator lamp "Regeneration I" begins to flash rapidly. The controller's internal clock then switches from minute impulses to second impulses. The time set for the current regeneration is speeded up accordingly until the end of the stage is reached. The controller then switches to the next stage and continues at normal speed. After waiting 1 minute the fast run can be started again by pressing the "Reg. manual" and "Key" buttons. This procedure can be repeated until the end of the regeneration program.

REGENERATION STOP

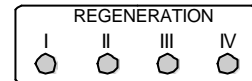
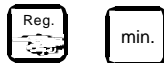

Press the blue "Reg. manual" button and the "min." button until none of the red indicator lamps "Regeneration I - IV" light up.

Important note!

When multi-stage valves are installed the regeneration control valve may remain stationary in its current position.

FILTER CHANGE-OVER WITHOUT STARTING PROGRAM

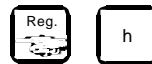

Press the blue "Reg. manual" button and the "h" button for approximately 5 seconds until the indicator lamp for filter 1 or filter 2 lights up.

Important note!

The display and the storage values of the residual quantity of soft water remain unchanged with each filter change.

ADDITIONAL CONNECTION FACILITY (MMP 70 only)

PROGRAM INDICATOR (*REGENERATION*)

A pilot lamp can be connected for external indication of the program sequence or for the control of a contactor or solenoid valve during the program sequence (regeneration). The signal is maintained until the regeneration program and all supplementary programs have come to an end.

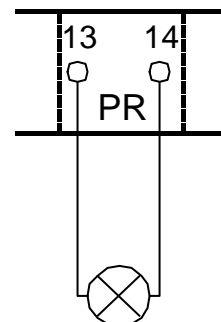

EXAMPLE OF CIRCUITRY

Single filter plant with PS valve, terminal diagram MMP 70 230V/24V

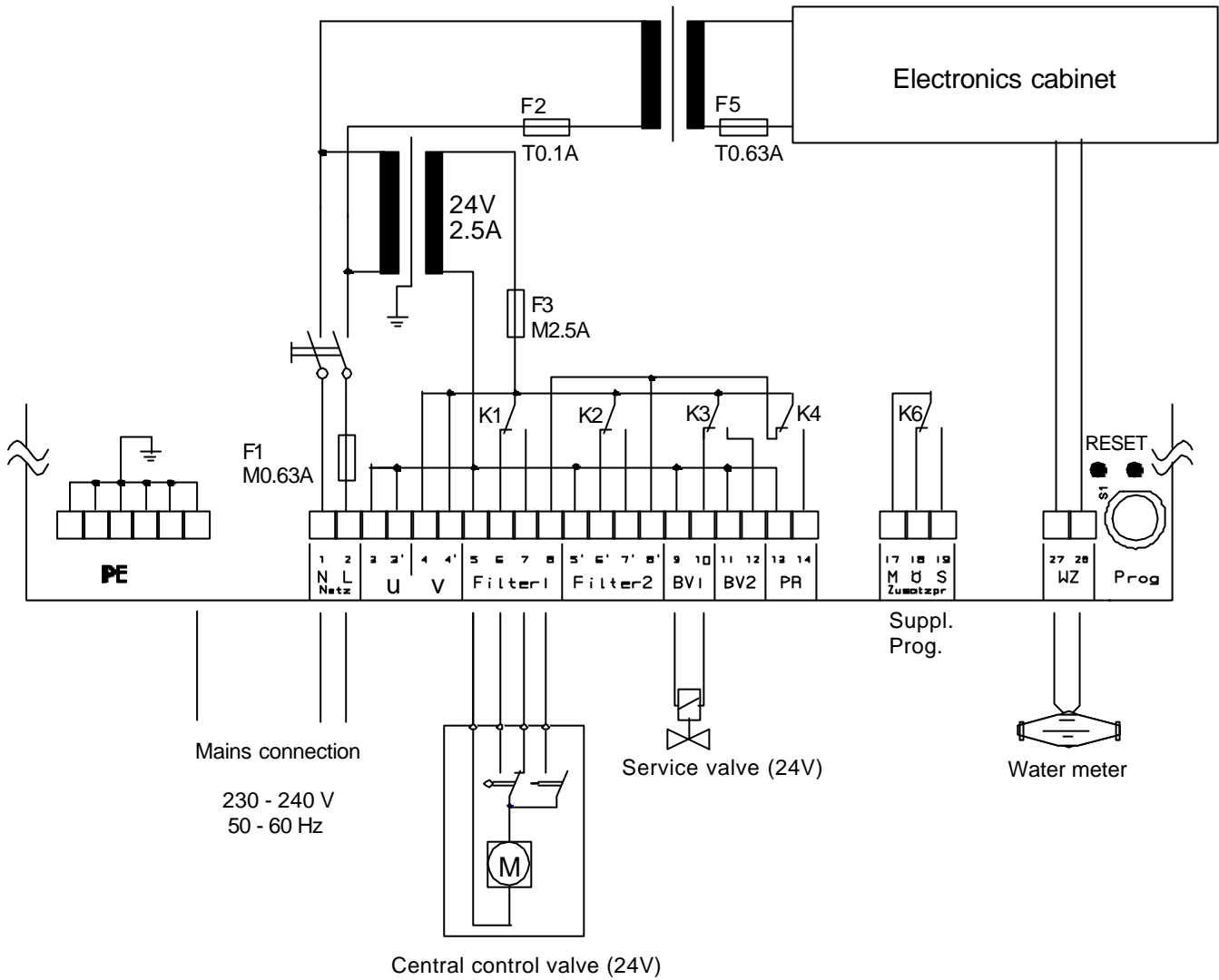

GUIDE TO TYPICAL CIRCUIT

SINGLE FILTER PLANT WITH PS-VALVE

BASIC PROGRAMMING

1. Operation mode: 'Single' filter

Data input:

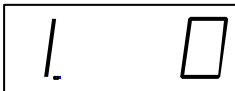

2. Regeneration delay: The plant must not regenerate during the day because soft water is in constant demand during production time.

Data input:



3. Electrical control of the regeneration valves: The plant is operated with a valve for partial salting.

Data input:



4. Premature regeneration triggering: The plant is supplied with 40 litres of resin corresponding to a specific capacity of 2500 g CaCO₃. At 250 ppm CaCO₃ the plant supplies 10 m³ of soft water between regenerations. To ensure that at least 3 m³ of soft water is available each day, the plant must regenerate after 7 m³ is consumed. This corresponds to a premature regeneration with 30% of soft water in reserve.

Data input:

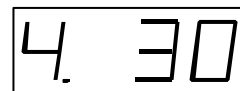

5. Supplementary program: The supplementary program is not required.

Data input:

5.000

6. Triggering supplementary program: This programming step is not displayed as 0 was entered in step 5.

7. Impulse emitting water meter: The plant has a water meter that emits an impulse after every 10 litres.

Data input:

7. 4

8. Plant capacity (00--): The plant has a specific capacity of 2500 g CaCO₃. Enter 02 in programming step 8 and 500 in step 9.

Data input:

8. 02

9. Plant capacity(--000):

Data input:

9.500

10. Regeneration time stage I: In position 1 the brine is extracted in 55 minutes with the PS valve, when the resin bed is completely exhausted. With premature regeneration the extraction time is computed according to filter exhaustion.

Data input:

10.55

11. Regeneration time stage II: In position 2 there is a purge cycle of 10 minutes with the PS valve.

Data input:

11.10

12. Regeneration time stage III: In position 3 the plant is back-washed in 25 minutes with the PS valve.

Data input:

12.25

13. Regeneration time stage IV: This stage is not required for the valve and is not displayed.

OPERATING DATA

Raw water hardness: The raw water hardness is 250 ppm CaCO₃.

Data input:

250

Time: Enter the current time, e.g. 11.54.

Data input:

11.54

Interval triggering: To prevent bacteriological contamination during long idle periods, a regeneration cycle should be started at least every 3 days.

Data input:

03

Regeneration delay: Automatic regeneration should be avoided before 18.30.

Data input:

18.30

EXAMPLE OF CIRCUITRY

Alternate filter plant with 4-stage valve, terminal diagram MMP 70

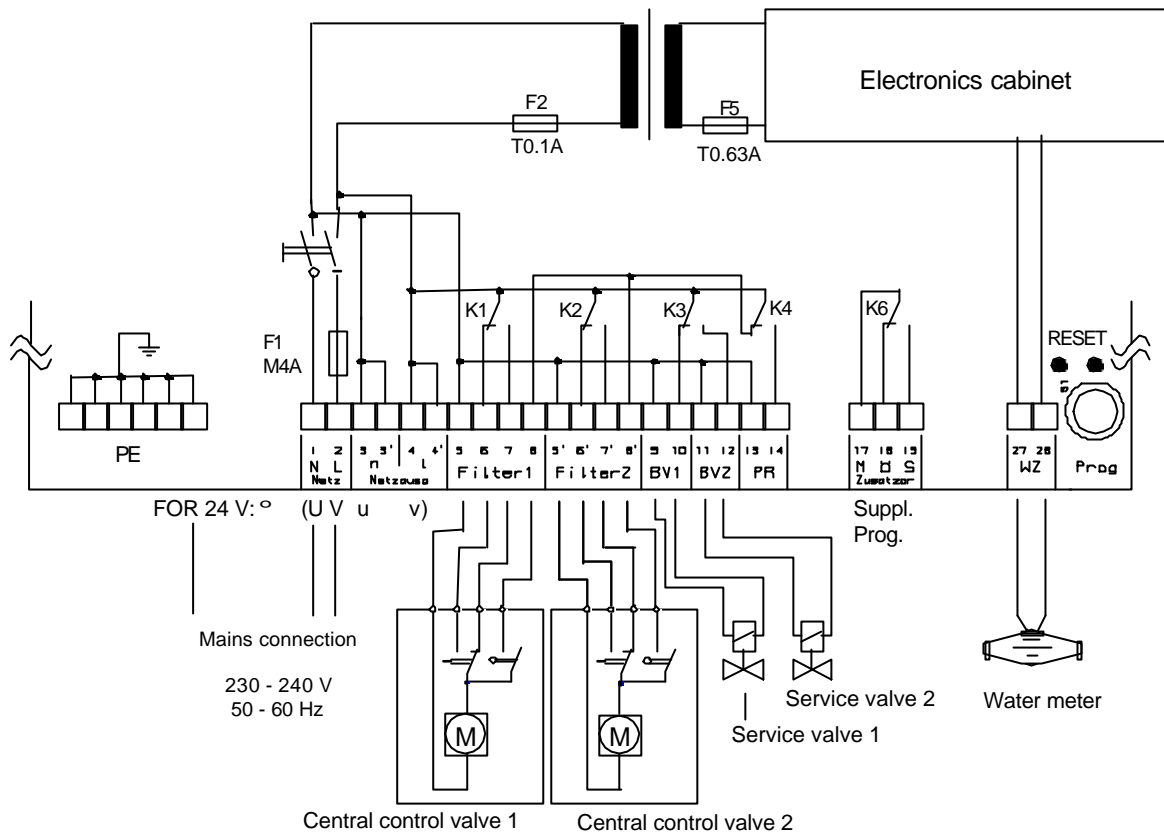

GUIDE TO TYPICAL CIRCUIT

'Alternate' filter plant with 4-stage valve

BASIC PROGRAMMING

1. Operation mode: 'Alternate' filter mode

Data input:

2. Regeneration delay: The plant should be regenerated without a time delay.

Data input:

3. Electrical control of the regeneration valves: The plant is operated with two 4-stage valves.

Data input:

4. Premature regeneration triggering: The plant should be regenerated when exhausted.

Data input:

5. Supplementary program: A brine valve must remain open for 46 minutes during the regeneration cycle.

Data input:

6. Triggering supplementary program: The brine valve must open at the start of regeneration stage II (brine-draw).

Data input:

7. Impulse-emitting water meter: The plant has a water meter that emits an impulse after every 100 litres.

Data input:

8. Plant capacity (00--): The plant has a specific capacity of 4100 g CaCO₃. Enter 4 in programming step 8 and 100 in step 9.

Data input:

9. Plant capacity (--000):

Data input:

10. Regeneration time stage I: In position 1 there is a 10 minute Backflush is carried out.

Data input:

11. Regeneration time stage II: In position 2 the brine is drawn-off. The time set is 60 minutes. In the supplementary program (5) the brine valve closes after 46 minutes, leaving 14 minutes for the "Slow Rinse" phase.

Data input:

12. Regeneration time stage III: In position 3 a fast-rinse time of 15 minutes is entered.

Data input:

13. Regeneration time stage IV: This stage is not required for the valve and is not displayed.

OPERATING DATA

Raw water hardness: Assuming the raw water hardness is 250 ppm CaCO₃ and a blend hardness of 50 ppm CaCO₃ was set at the regeneration control valve, an untreated water hardness of 200 ppm CaCO₃ must be entered.

Data input:

Time: Enter the current time, e.g. 8.40.

Data input:

Interval triggering: The plant should not regenerate at fixed day intervals.

Data input:

Regeneration delay: No regeneration delay was entered in basic programming step 2, i.e. no display.

EXAMPLE OF CIRCUITRY

Alternate filter plant with 4-stage valve, terminal diagram MMP 71

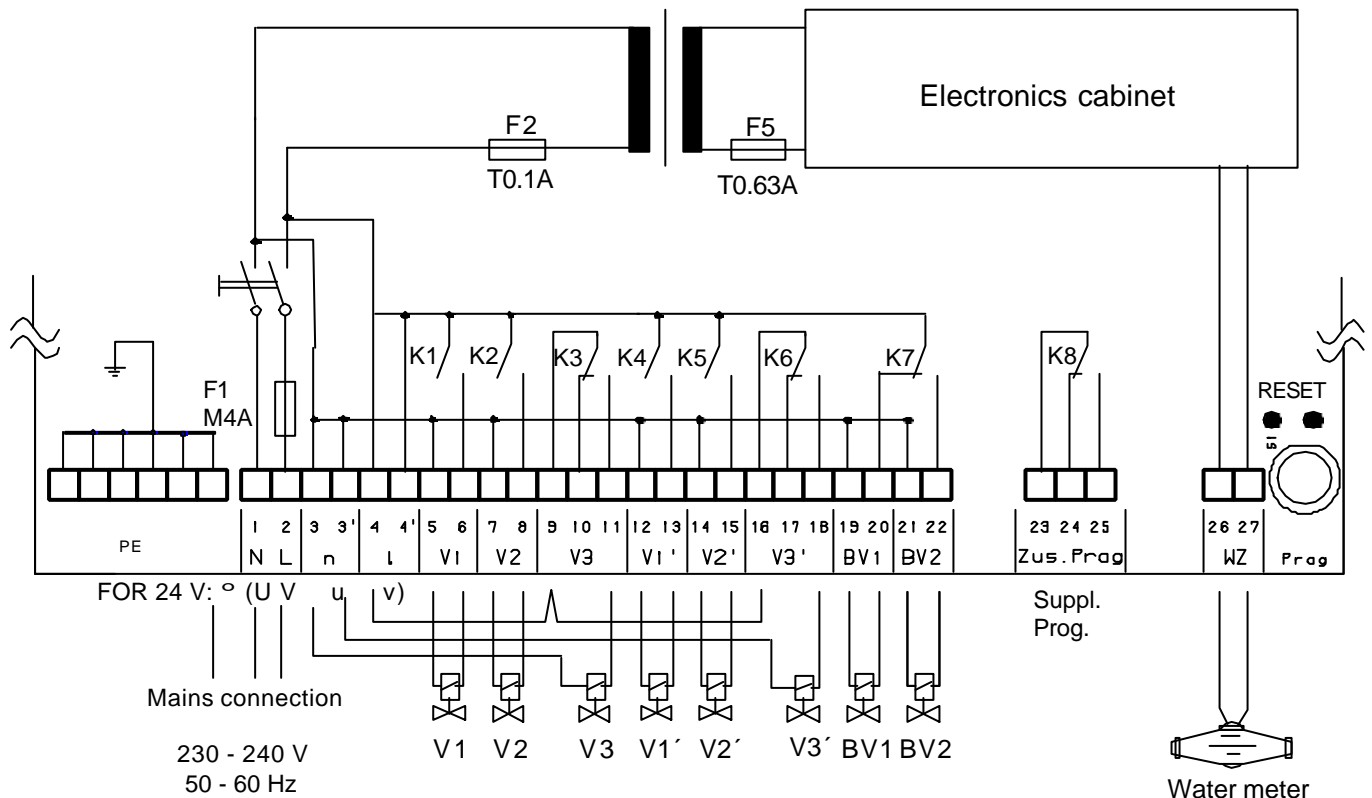

PROGRAMMING DATA

Basic programming data							MMP 71	Service	
1. <input type="text"/>	2. <input type="text"/>	3. <input type="text"/>	4. <input type="text"/>	5. <input type="text"/>	6. <input type="text"/>	7. <input type="text"/>		I	<input type="text"/>
Operating mode	Reg. delay	Reg. valve control	Premature reg.	Suppl. prog.	Triggering suppl. prog.	Water meter		II	<input type="text"/>
8. <input type="text"/>	9. <input type="text"/>	10. <input type="text"/>	11. <input type="text"/>	12. <input type="text"/>	13. <input type="text"/>			III	<input type="text"/>
Cap. (00_)	Cap. (_00)	Reg. time I	Reg. time II	Reg. time III	Reg. time IV		IV	<input type="text"/>	
<input type="text"/>	Hardness <input type="text"/>	@ <input type="text"/>	Days <input type="text"/>	Reg.- @ <input type="text"/>					

TECHNICAL DATA

Power supply: 230 - 240 V or 24V+/-10%, 50 - 60 Hz, fuse M4A

Power input excluding external load: 7VA

Enclosure protection: IP54

Ambient temperature: 0 - 45EC



Conformity: EN 50081-1, EN 50082-2, EN 61010-1

Dimensions, surface mounted model

MMP 70 / MMP 71: W x H x D = 265 x 225 x 150 mm

Dimensions, flush mounted model

MMP 70 E / MMP 71 E:

Flush mounted enclosure to DIN 43700 made of glass fibre reinforced Noryl.
Front panel 192 x 144 mm, recess 122 mm,
control panel cut-out 186 x 138 + 1.0 mm

Weight: 1.9 kg (MMP 70/71) / 2.5 kg (MMP 70 230V/24V)

Connection for: Regeneration control valves or pilot distributors, service valves.
Load on contacts max. 2A ohmic (resistive load).
The MMP 70 230V/24V runs on 24V(!), the other models on mains voltage.

Connection for: Supplementary program
Load on contacts max. 240V, 2A ohmic (resistive load)

Connection for: Impulse emitting water meter
Load on contacts max. 12V 16mA
minimum impulse interval of 0.2 seconds

Basic programming memory: EEPROM

We reserve the right to make technical changes without notice in the interest of constantly improving our products !