

ROE 900

ROE 901

Microprocessor controllers
for Reverse Osmosis Plants



Operating instructions

CONTENTS

GENERAL NOTES	1
Description of displays, indicators and operating features	1
Installation and commissioning	1
MODE OF OPERATION	2
Service	2
Standby	2
Hour meter	2
Pressure pump (Connection "PUMPE")	2
Post flush (Connection "SPÜLEN")	2
Flush interval	3
Inlet valve (Connection "E-VENTIL")	3
Outlet valve (Connection "A-VENTIL"; ROE 901 only!)	3
Start/Stop flush (ROE 901 only!)	3
Faults (Connection "ALARM")	3
Conductivity (Connection "SONDE")	4
External triggering (Connections "VOLL" und "LEER")	4
Excess water-pressure (Connection "ÜBERDRUCK")	4
Low water-Pressure (Connection "WASSERMANGEL")	5
Stop Service (Connection "STOP")	5
Concentrate (Connection "KONZ")	5
Power failure	5
Maintenance	5
BASIC PROGRAMMING	6
1. Flushing time	6
2. Cell constant	6
3. Limit value conductivity min.	7
4. Limit value conductivity max.	8
5. Plant shut-down using the conductivity settings	8
6. Conductivity max. delay	9
7. Flush interval	9
8. Interval flush duration	9
LITTLE HELP	10
TECHNICAL APPENDIX	10
Diagram of Reverse Osmosis plant	10
Example of circuitry for ROE 900	11
Example of circuitry for ROE 901	11
Status and flow chart for ROE 900/ROE 901	12
BASIC PROGRAMMING DATA	Cover
TECHNICAL DATA	Cover

GENERAL NOTES

DESCRIPTION OF DISPLAYS, INDICATORS AND OPERATING FEATURES

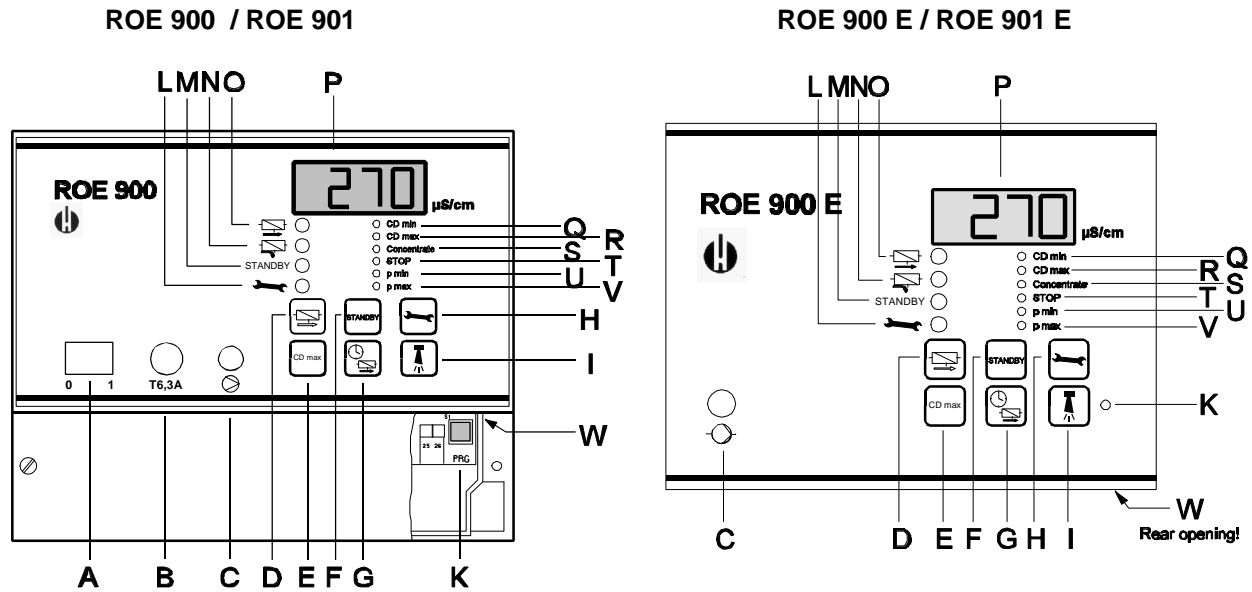

- | | | | |
|---|----------------------------|---|-------------------------------------|
| A | - Power switch | M | - "Standby" indicator |
| B | - Fuse 6.3A | N | - "Flush" indicator |
| C | - Thermal release | O | - "Service" indicator |
| D | - "Service" button | P | - Display window |
| E | - "Limit value CD" button | Q | - "Conductivity Min." indicator |
| F | - "Standby" button | R | - "Conductivity Max." indicator |
| G | - "Operating hours" button | S | - "Concentrate" indicator |
| H | - "Maintenance" button | T | - "STOP" indicator |
| I | - "Fault off" button | U | - "Low water-pressure" indicator |
| K | - Security button | V | - "Excess water-pressure" indicator |
| L | - "Maintenance" indicator | W | - Reset pins (located internally) |

INSTALLATION AND COMMISSIONING

The installation and commissioning should be carried out by qualified personnel!

The controller must be installed in compliance with the parameters stated in the technical data (e.g. ambient temperature) and operated to comply with the relevant standards (DIN, VDE, UVV) or in accordance with the regulations laid down by the individual country.

Protect the controller against excessive humidity, condensation and water-splash.

The cables connected to the sensors should be kept as short as possible and **clear of** power cables. In the vicinity of sources of strong electromagnetic radiation the instrument reading may be affected. In such cases separate measures must be taken to suppress interference.

Operate the controller strictly in accordance with the manufacturer's instructions.

After installation the next step is to reprogrammed the controller with the plant-specific characteristics and data as

The basic data remains in permanent memory and is unaffected by power failure.

MODE OF OPERATION

SERVICE

The pressure pump of the reverse osmosis plant can be switched on and off using the "Service" and "Standby" buttons. When the "Service" button is pressed the relevant indicator lights up, the inlet valve opens and after a 10 second delay the pressure pump motor starts up. During Service raw water pressure on the primary side of the pump (run-dry protection) and pressure on the secondary side of the pump (excess pressure protection) can be monitored with pressure monitors and the concentrate (concentrate flow rate) can be monitored with a flow meter, provided that the plant is fitted with appropriate sensors. In addition to this, the conductivity of the permeate is measured, indicated and compared with a minimum and maximum limit value.

If the plant is fitted with a supply tank the pump can also be switched on and off automatically by a level sensor in the tank.

Service can also be temporarily halted by means of an external switch in order, for example, to allow an upstream water softening plant to be regenerated.

STANDBY

Press the "Standby" button when no more water is needed. This switches off the pressure pump motor and the "Standby" indicator lights up. In plants fitted with a flushing valve a post flushing stage is interposed before the "Standby" position is reached. During flushing the indicator "Flush" is lit.

While the plant is switching from service to flush the pressure pump is switched off for 5 seconds with the inlet and flushing valves open in order to equalise pressure.

When the plant is in the "Standby" position water pressure on the primary and secondary side of the pressure pump, concentrate flow and conductivity limit values are not monitored.

If the plant is fitted with a supply tank the pump can also be switched on and off automatically by a level sensor in the tank.

HOUR METER

A built-in hour meter counts the operating hours during which the pressure pump has been in service and accordingly is an indication of load on the modules. Press the "Operating hours" button to call up the current value in the display window.

To reset the hour meter:

Keep the "Operating hours" button depressed and briefly bridge the two reset pins (cf. illustration on page 1).

PRESSURE PUMP (Connection "PUMPE")

Motors of various power ratings can be used to drive the pressure pump. The motor is protected by a 6.3 A fuse and a replaceable thermal m.c.b. for rated currents of 0.1 to 6 A which can be adapted to the power of the pump motor. The standard version is fitted with a 4 A m.c.b. For three phase motors an appropriate power contactor must be fitted in addition.

The inlet valve always opens when service is activated. The pressure pump starts up after a delay of 10 seconds.

POST FLUSH (Connection "SPÜLEN")

In order to preclude excessive deposits on the modules the plant can be fitted with a flush valve (ROE 900 connection 9/10, ROE 901 connection 11/12)

Flushing time can be set to between 0 and 99 minutes in programming step 1 of the basic programming.

Flushing is aborted when the "Service" button is pressed or water is called for by a level switch in the supply tank.

FLUSH INTERVAL

A flush can be carried out at set intervals after the plant was last switched to "Standby". Interval flushing prevents excessive bacteriological contamination of the modules. The interval (0 - 99 hours) and flushing time (1 - 99 minutes) are entered in the programming steps 7 and 8 of the basic programming. Flushing is aborted when the "Service" button is pressed or water is called for by a level switch in the supply tank. In the case of stop service resulting no flush interval.

INLET VALVE (Connection "E-VENTIL")

The inlet valve must be designed to open when control voltage is applied. When the plant is switched to "Service" the inlet valve is opened first. The pressure pump starts up after a delay of 10 seconds.

OUTLET VALVE (Connection "A-VENTIL" ROE 901 only!)

The ROE 901 is fitted with a connection for an outlet valve. This valve remains closed until the conductivity of the water drops below the set limit value "Conductivity max.". Instead of the outlet valve a flushing valve may be fitted which closes when voltage is applied. It is also possible to install both types of valve.

START/STOP FLUSH (ROE 901 only!)

In the case of the ROE 901 flushing can be started and stopped separately. To start a flush press the "Limit value CD" and "Service" buttons simultaneously. To stop a flush press the "Limit value CD" and "Standby" buttons simultaneously.

FAULTS (Connection "ALARM")

The following faults are indicated provided that the plant has been fitted with the relevant sensors:

1. "Low water-pressure" = raw water pressure on the primary side of the pump (response time = 10 seconds)
2. "Excess water-pressure" = raw water pressure on the secondary side of the pump (response time = 2 seconds)
3. "Concentrate" = concentrate flow at the outlet of the module (response time = 30 seconds)

In addition to this a built-in conductivity meter monitors the conductivity of the permeate:

4. "Conductivity min." (response time = 20 seconds)
5. "Conductivity max." (response time = 0 - 25.5 minutes)

The sensor inputs have set response times in accordance with the table above. The response time for the fault indicator "Conductivity min." has been set to 20 seconds. The response time for the fault indicator "Conductivity max." can be freely set between 0 and 25.5 minutes in programming step 6 of the basic programming.

If the sensors transmit a fault message the plant is switched off on expiry of the response time. In programming step 5 you can stipulate whether the plant is to be switched off when the conductivity limit values are reached.

A **volt-free alarm** contact (group fault via terminal connections "Alarm") is available for all fault messages. A horn can be attached as shown in the circuitry example for ROE 900 / ROE 901 in the Technical Appendix of this manual.

Press the "Fault off" button to clear the alarm (relay output). The fault message cannot be cleared until the fault is remedied.

CONDUCTIVITY (Connection “SONDE”)

The ROE 900 and ROE 901 controllers are fitted with a digital conductivity meter to monitor the permeate. In programming step 3 of the basic programming a minimum value for conductivity is to be set below which conductivity cannot drop owing to the quality of the raw water. If the value does drop below this minimum there will be a fault in the plant or the controller. The electrical connection between the controller and sensor may, for example, be broken.

In programming step 4 of the basic programming a maximum conductivity value is set to guarantee adequate water quality.

Different measuring ranges can be implemented by connecting sensors with different cell constants.

In programming step 2 you can stipulate which sensors are used. In accordance with the sensors used the following measuring ranges will be applicable:

ROE 900		ROE 901	
Cell constant	Measuring range	Cell constant	Measuring range
1.0/cm	0 to 200 µS/cm	1.0/cm	0 to 2000 µS/cm
0.5/cm	0 to 100 µS/cm	0.5/cm	0 to 1000 µS/cm
0.1/cm	0 to 20.0 µS/cm	0.1/cm	0 to 200.0µS/cm
		0.01/cm	0 to 20.00 µS/cm

If the measuring range is exceeded the message "OFL" will appear on the display.

EXTERNAL TRIGGERING (Connection “VOLL” and “LEER”)

Connections for level sensors (full, empty) are fitted to regulate, for instance, a supply tank. As soon as the lower level "Tank empty" (connection "LEER") is reached the sensor contact closes and the plant is switched on. It will not be switched off again until the upper level "Tank full" (connection "VOLL") is reached and the contact of this sensor opens. Instead of two level switches it is possible to work with only one upper level switch (float switch) or one remote switch (Service/Standby). The connection "LEER" must then be bridged.

This has the effect of disabling the "Service" and "Standby" buttons.

Important note !

When concentrate is displaced automatically by permeate (flushing) account must be taken of the fact that soft water may still be able to run into the supply tank up until the end of the flush, depending on the pressure in the system. The upper level switch must accordingly be positioned so as to prevent the tank overflowing. For safety reasons the tank should always be fitted with an overflow pipe to the drains.

Important note !

If no level switch is fitted the connection "VOLL" must be bridged. The connection "LEER" must **not** be bridged.

EXCESS WATER-PRESSURE (Connection “ÜBERDRUCK”)

To protect the module an excess water-pressure monitor can be installed either on the raw water side or the soft water side. Two pressure monitors can also be connected in series. If the limit value is reached the plant is switched off after a delay of 2 seconds and the fault indicator "Excess water-pressure" lights up. The plant can be switched on again using the "Service" button. If there is still excess water-pressure the plant will be switched off again after a delay of 2 seconds.

Important note !

If the plant is not fitted with an Excess water-pressure monitor the connection "ÜBERDRUCK" must be bridged

LOW WATER-PRESSURE (Connection “WASSERMANGEL”)

A pressure monitor can be built in to the suction line to prevent the pressure pump from running dry. If pressure falls below the lower limit value the plant will be switched off after a delay of 10 seconds and the indicator "Low water-pressure" will light up. Connection is made to the connection "WASSERMANGEL". The plant can be switched on again by pressing the "Service" button.

If water is still low the plant will be switched off again after a delay of 10 seconds.

Important note !

If the plant is fitted with level switches (cf. external contacts) to control the replenishment of a supply tank, the pressure pump will be switched on again 10 minutes after it has been switched off by the dry-run switch. If water is still low the plant will be switched off again after 10 seconds. When the plant has been switched on and off **three times** owing to water being low it will finally shut-down. The plant can then only be switched on again by pressing the "Service" button.

Important note !

If no pressure monitor is installed the connection "WASSERMANGEL" must be bridged.

STOP SERVICE (Connection “STOP”)

It may be necessary to halt service by means of an external switch. For example, if a single filter water softening plant is connected upstream of the Reverse Osmosis plant, it should not service desalinated water while the filter is being regenerated in order to ensure that hard water is not fed to the modules.

The "Stop Service" function holds back the flush interval.

CONCENTRATE (Connection “VOLL” and “LEER”)

To protect the module, concentrate flow can be monitored by a flow meter with a limit contact sensor. If flow drops below a set limit the plant is switched off after a delay of 30 seconds and the fault indicator "Concentrate" lights up. The plant can be switched on again using the "Service" button. If the flow rate is still too low the plant will be switched off again after a 30 second delay.

Important note !

If no concentrate flow monitor is fitted the connection "KONZ" must be bridged.

POWER FAILURE

When power returns after a failure the plant will automatically go to Standby. Before the Standby position is reached a flush will be carried out for the time entered in programming step 1 of basic programming. The plant can be either switched on manually using the "Service" button or automatically by, for instance, a level sensor in the supply tank. When the unit is switched off and on again at the mains the same procedure applies.

MAINTENANCE

There is a separate program for maintenance which should only be activated by trained personnel. This is activated by first pressing the "Standby" button and then keeping the "Maintenance" and "Fault off" buttons depressed for 10 seconds. In this setting the automatic replenishment of a supply tank, dry-run monitoring and concentrate monitoring are switched off and the conductivity limit values are no longer monitored.

The pressure pump can be switched on and off using the "Service" and "Standby" buttons (in order, to carry out membrane disinfection). If a flushing valve is fitted it will remain open for as long as the pump is running irrespective of the flushing time that has been set.

From the "Standby" position normal functioning of the plant can be regained by briefly pressing the "Maintenance" button.

Information on what maintenance is to be carried out and at what intervals should be given by the installer in the Reverse Osmosis Plant Maintenance Manual.

BASIC PROGRAMMING

Be sure to make a note of your basic programming data on the sticker in the terminal box cover and on the last page of this manual.

To return all the data entered to the **PRE-SET VALUES**, bridge the two **RESET** pins while simultaneously holding down the "PROG" button.

Operating data (programming steps 1 - 8) is to be entered in the sequence described below:

ROE 900 /901 surface mounted unit: Open the terminal box cover and press the red security button (cf. page 1)
ROE 900 E /901 E flush mounted unit: Open the front panel door and press the red security button next to the "Fault off" button using a slender implement (cf. page 1)

This enables changes to be made in the basic programming:

The display window will then show for example, "1.06". This means that the programming step 1 = flushing time has been set to the value 06 = 6 minutes. For instance, if you want to change the flushing time to 10 minutes, keep the red security button depressed and press the "Operating hours" button until "1.10" appears in the display. If you want to change the next programming step = cell constant, keep the red security button depressed and press the "Fault off" button. The following values, for example, will then be displayed: "2.1.0" = Cell constant 1/cm or "2.0.5" = cell constant 0.5/cm or "2.0.1" = cell constant 0.1/cm.

In the programming menu, the following basic data can be entered in the appropriate programming steps where they are held until a new basic program is entered:

PROGRAMMING STEP 1 *FLUSHING TIME*

Press the red security button until, for example, the following is displayed:

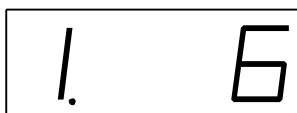

Flushing time = 6 minutes

To enter the flushing time you want keep the red security button depressed while pressing the "Operating hours" button for the units and the "Limit value CD" button for the tens.

Values from 0 to 99 minutes can be entered. (Pre-setting is 10)

If a 0 is entered no flush will be carried out when the plant switches to "Standby".

PROGRAMMING STEP 2 CELL CONSTANT

The cell constant values you set must accord with the values of the sensor connected to the system.

Keep the red security button depressed while pressing the "Fault off" button until, for example, the following is displayed:



Cell constant = 1.0/cm

Keep the red security button depressed while pressing the "Operating hours" button to select the desired cell constant. (Pre-setting is 1.0)

The measuring ranges will be in accordance with the cell constant you enter, as follows:

ROE 900		ROE 901	
Cell constant	Measuring range	Cell constant	Measuring range
1.0/cm	0 to 200 μ S/cm	1.0/cm	0 to 2000 μ S/cm
0.5/cm	0 to 100 μ S/cm	0.5/cm	0 to 1000 μ S/cm
0.1/cm	0 to 20.0 μ S/cm	0.1/cm	0 to 200.0 μ S/cm
		0.01/cm	0 to 20.00 μ S/cm

PROGRAMMING STEP 3 LIMIT VALUE CONDUCTIVITY MIN.

If a limit value of 0 μ S/cm is entered, there will be no monitoring of minimum conductivity.

Keep the red security button depressed while pressing the "Fault off" button until, for example, the following is displayed:



Limit value for minimum conductivity = 10 μ S/cm

To enter the limit value you want keep the red security button depressed while pressing the "Operating hours" button for the units and the "Limit value conductivity" button for the tens and hundreds. (Pre-setting is 100)

The values entered can have a maximum of three digits.

Depending on the values entered in programming step 2 = cell constant, the following limit values can be set:

ROE 900		ROE 901	
Cell constant	Limit value min.	Cell constant	Limit value min.
1.0/cm	0 to 200 μ S/cm	1.0/cm	0 to 999 μ S/cm
0.5/cm	0 to 100 μ S/cm	0.5/cm	0 to 999 μ S/cm
0.1/cm	0 to 20.0 μ S/cm	0.1/cm	0.0 to 99.9 μ S/cm
		0.01/cm	0.00 to 9.99 μ S/cm

PROGRAMMING STEP 4 LIMIT VALUE CONDUCTIVITY MAX.

No values can be entered here that are less than the value entered in the programming step 3 = limit value conductivity min.

Keep the red security button pressed while pressing the "Fault off" button until, for example, the following is displayed:

4. 30

Limit value for maximum conductivity = 30 μ S/cm

To enter the limit value you want keep the red security button depressed while pressing the "Operating hours" button for the units and the "Limit value conductivity" button for the tens and hundreds.
(Pre-setting is for ROE 900: 150, for ROE 901: 0.150)

ROE 901 only:

If a 4 digit limit value is to be entered, but the display only has four positions, the display figure (4.) has been left out of programming step 4. The final decimal point flashes to mark programming step 4.

Depending on the values entered in programming step 2 = cell constant, the following limit values can be set:

ROE 900		ROE 901	
Cell constant	Limit value max.	Cell constant	Limit value max.
1.0/cm	2 to 200 μ S/cm	1.0/cm	2 to 2000 μ S/cm
0.5/cm	2 to 100 μ S/cm	0.5/cm	2 to 1000 μ S/cm
0.1/cm	0.2 to 20.0 μ S/cm	0.1/cm	0.2 to 200.0 μ S/cm
		0.01/cm	0.02 to 20.00 μ S/cm

PROGRAMMING STEP 5 SWITCH THE PLANT OFF USING THE CONDUCTIVITY SETTINGS

Keep the red security button depressed while pressing the "Fault off" button until, for example, the following is displayed:

value 5. 4

Switch off when below minimum limit value or above maximum limit

To set the plant to be switched off by this method keep the red security button depressed while pressing the "Operating hours" button. (Pre-setting is 1)

This programming step selects whether the plant is to be switched off when the value falls below that entered in programming step 3 = limit value conductivity min. and rises above the value set in programming step 4 = limit value conductivity max.

If no monitoring of conductivity min. has been selected in programming step 3 the values 2 and 4 cannot be entered here.

The following table is used to stipulate whether the plant is to be shut down when a limit value is reached.

ENTER VALUE	1	2	3	4
Limit value min.	No	Yes	No	Yes
Limit value max.	No	No	Yes	Yes

No = plant not switched off

Yes = plant switched off

PROGRAMMING STEP 6 CONDUCTIVITY MAX. DELAY

Keep the red security button depressed and press the "Fault off" button until, for example, the following is displayed:

A digital display showing the number '6.' followed by '20'.

Delay = 2.0 minutes

To enter the delay you want keep the red security button depressed while pressing the "Operating hours" button for tenths of minutes and the "Limit value conductivity" button for full minutes.

Values from 0 to 25.5 minutes can be entered for the length of delay after the maximum limit value is exceeded. (Pre-setting is 00.0)

There is a fixed delay of 20 seconds for when the limit value falls below the pre-set minimum.

It is only after expiry of these set delays that "Conductivity min." and "Conductivity max." faults are indicated and *the plant is switched off in accordance with the values set in programming step 5.*

PROGRAMMING STEP 7 FLUSH INTERVAL

Keep the red security button depressed and press the "Fault off" button until, for example, the following is displayed:

A digital display showing the number '7.' followed by '24'.

Flush interval = 24 hours

To enter the interval you want keep the red security button depressed while pressing the "Operating hours" button for the units and the "Limit value CD" button for the tens.

Values from 0 - 99 hours can be entered. (Pre-setting is 00)

The interval you enter here stipulates the fixed interval at which a flush will be triggered if water ceases to be drawn off.

If you enter a 0 there will be no interval flush.

The duration of the flush is entered in programming step 8 = *Interval flush duration.*

PROGRAMMING STEP 8 INTERVAL FLUSH DURATION

This programming step cannot be selected if a 0 = no flush has been entered in programming step 7 = flush interval.

Keep the red security button depressed while pressing the "Fault off" button until, for example, the following is displayed:

A digital display showing the number '8.' followed by '03'.

Interval flush duration = 3 minutes

To enter the interval flush duration you want keep the red security button depressed while pressing the "Operating hours" button for the units and the "Limit value CD" button for the tens.

Values from 1 to 99 minutes can be entered. (Pre-setting is 10)

GENERAL NOTES

What happens when the STOP function is activated?

The pump is switched off and the inlet valve closed. The "Service" indicator is switched off and the "STOP" indicator lights up.

The interval flush duration is not interrupted; however, the following flush interval will not be triggered.

Delays

Low water-pressure: The controllers check whether this condition has existed continuously for 10 seconds. If so, an error message is signalled and the plant is switched off. A "Low water-pressure" condition lasting, for example, 6 seconds will have no effect. There is **no** summation of "Low water-pressure" times.

Priorities of level switches and buttons

In the case of controllers which are not fitted with level switches (connection "VOLL" bridged and connection "LEER" open) the plant is switched on using the "Service" button and switched off using the "Standby" button.

On controllers with one level switch "Full" (input "Empty" bridged) the "Service" and "Standby" buttons are disabled.

In plants regulated by controllers with one level switch several flushes may be triggered in succession.

The reason is that water slopping in the supply tank repeatedly activates the level switch "Full".

In the case of controllers with two level switches the plant can also be switched on using the "Service" button and switched off using the "Standby" button provided that the water level in the supply tank is between the upper and lower level switches.

TECHNICAL APPENDIX

DIAGRAM OF ROE 900 / 901 REVERSE OSMOSIS PLANT

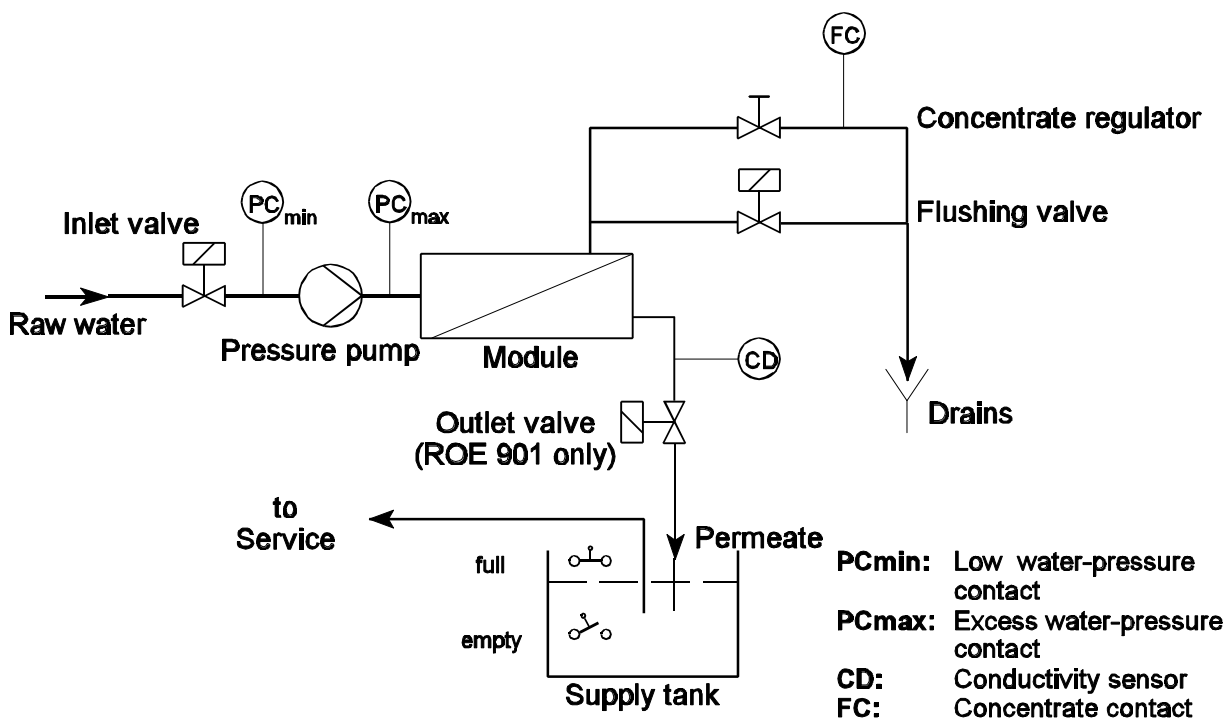

EXAMPLES OF CIRCUITRY

ROE 900

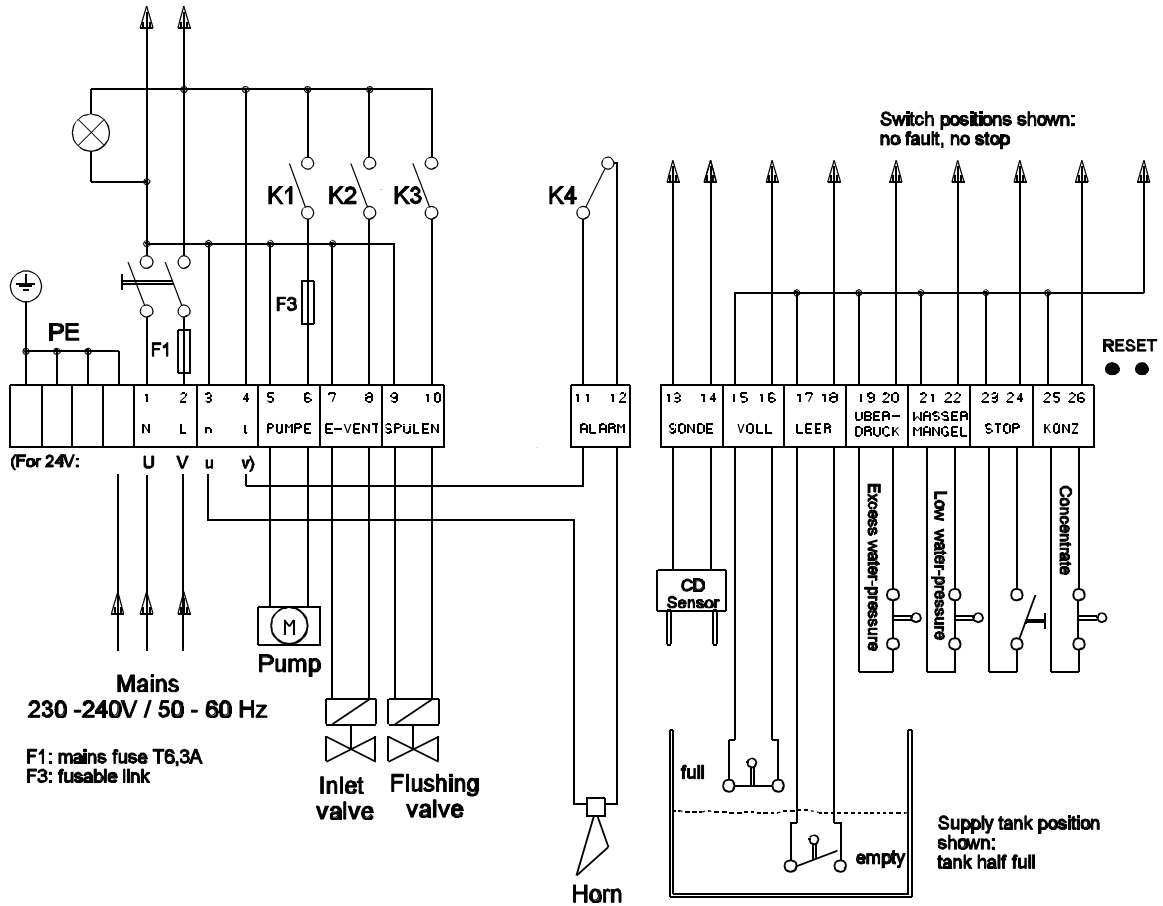

ROE 901

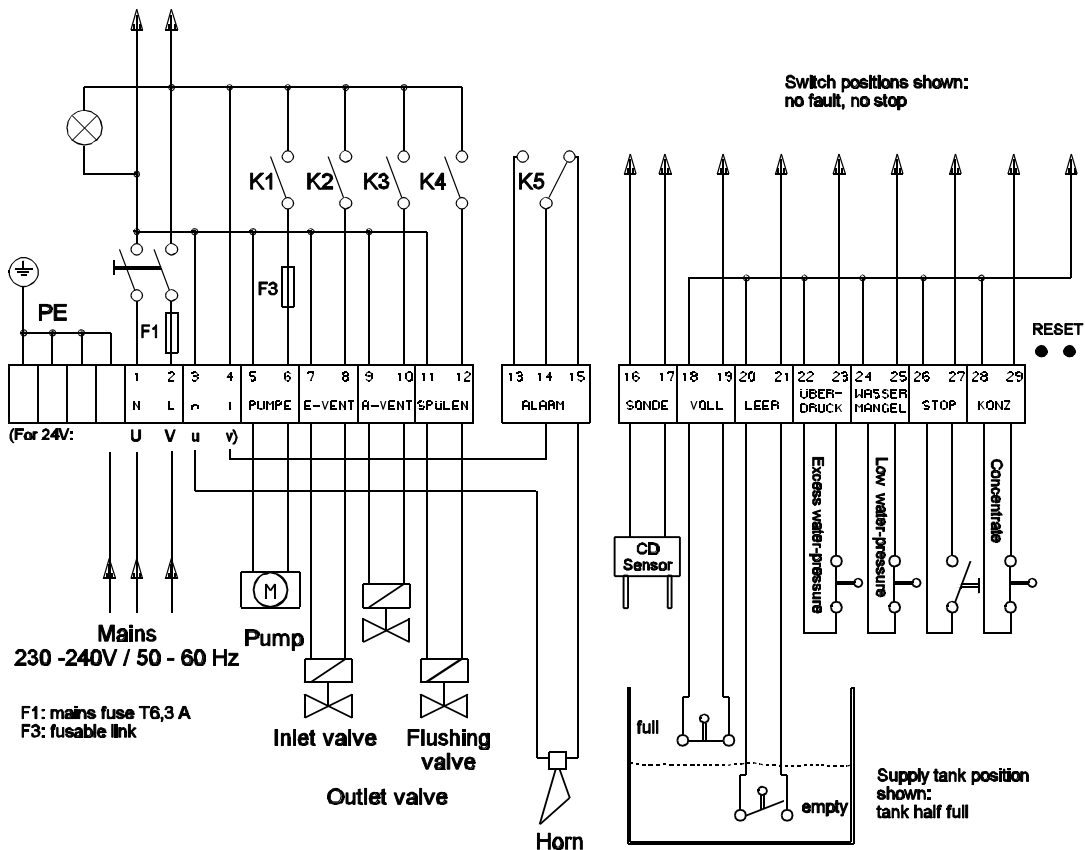

BASIC PROGRAMMING DATA

1. <input type="text"/>	2. <input type="text"/>	3. <input type="text"/>	4. <input type="text"/>	5. <input type="text"/>	6. <input type="text"/>	7. <input type="text"/>	8. <input type="text"/>
Flush time	Cell Constant	Cond. CD Min.	Cond. CD Max.	CD Control	CD Max. Delay	Flush interval	Flush duration

Entry Data for Basic programming

TECHNICAL DATA

Power supply: 230 - 240V or 24V +/-10% 50 - 60Hz, fuse T6,3A

Power input without external load: max. 15VA

Enclosure protection: IP 54

Ambient temperature: 0 - 45°C

Protection class: I

Conformity: EN 50081-1, EN 50082-2, EN 61010-1



Dimensions of ROE 900 and ROE 901 surface mounted enclosures:

W x H x D = 225 x 195 x 110mm

Dimensions of ROE 900 E and ROE 901 E flush mounted enclosures:

Flush mounted enclosure to DIN 43700 made of glass fibre reinforced Noryl. control panel cut out 186 x 138mm + 1,0mm, recess 122mm, front panel 192 x 144mm approx. 1.3 kg

Weight:

Connection for: Pressure pump (max. 0.8 kW), inlet valve, flushing valve (250V max. 1A)
ROE 901: outlet valve (250V max. 1A)

Connection for: Fault messages ROE 900: volt-free contact
ROE 901: volt-free changeover contact
load 250V max. 4A ohmic

Connection for: Excess water-pressure monitor, dry-run monitor, concentrate monitor, level sensor (load on all sensor contacts 5 V, 1 mA).

Measuring ranges depending on cell constants of sensors:

ROE 900		ROE 901		Sensor type
Cell constant	Measuring range	Cell constant	Measuring range	Designation
1.0/cm	0 to 200 µS/cm	1.0/cm	0 to 2000 µS/cm	SO10, SD10
0.5/cm	0 to 100 µS/cm	0.5/cm	0 to 1000 µS/cm	SO5, SOE5, SEI5
0.1/cm	0 to 20.0 µS/cm	0.1/cm	0 to 200.0 µS/cm	SO1, SOE1, SEI1
		0.01/cm	0 to 20.00 µS/cm	

Basic programming memory: EEPROM

We reserve the right to make technical changes without notice in the interests of constantly improving our products!